

Breakoutboard für UC400ETH

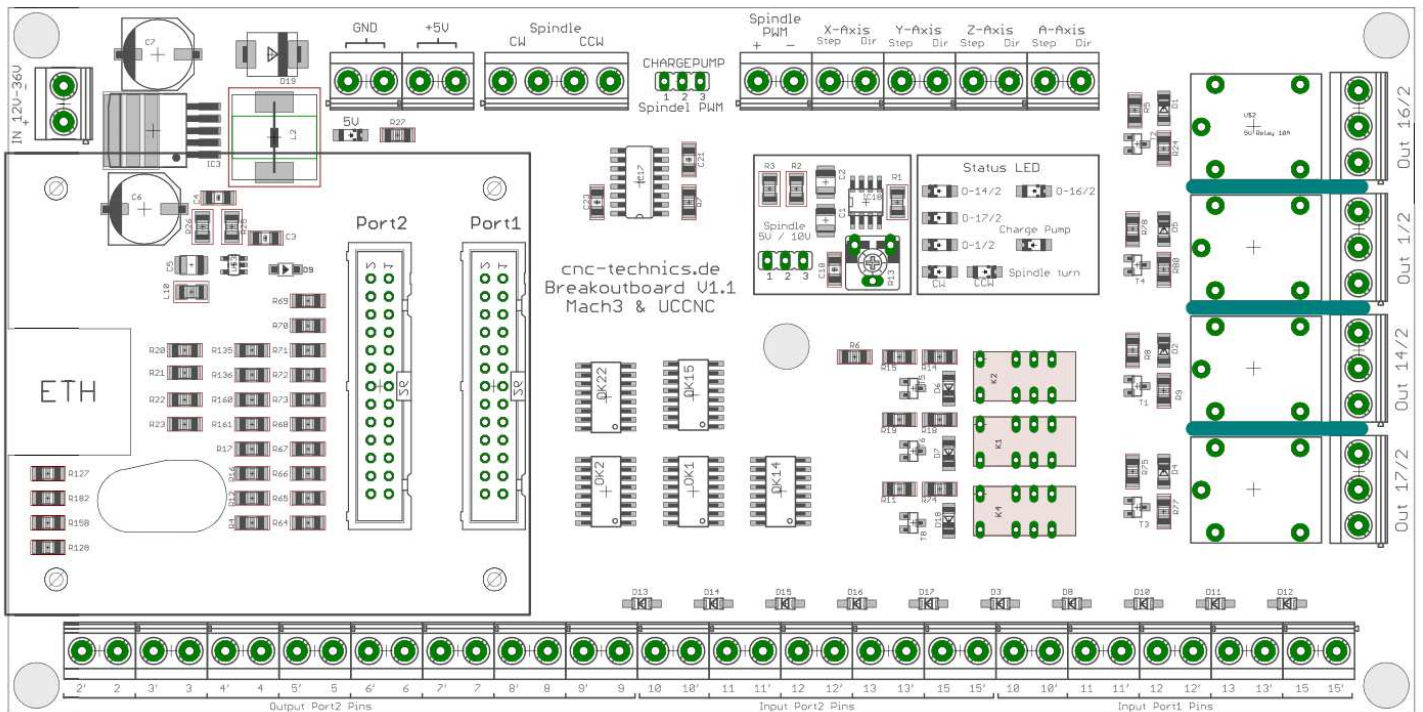

Operation Manual

All rights to these operating instructions remain with cnc-technics. Texts, information and illustrations of these operating instructions may not be reproduced, distributed or used for purposes of competition without authorization or communicated to others.

Table of Contents

Introduction	3
Delivery Parts	3
Description	4
Commissioning.....	5
Inputs	6
Outputs	8
Adjust the Axes	10
Adjust the Spindle	12
Spindle direction.....	13
Relay outputs.....	16
Status Display.....	17
Charge Pump.....	18

Introduction

This manual contains instructions for mounting, using the breakout board.

It is imperative to connect 230V connections by a knowledgeable electrician.

These operating instructions have been prepared with care. If you still find errors, we would be grateful for an indication.

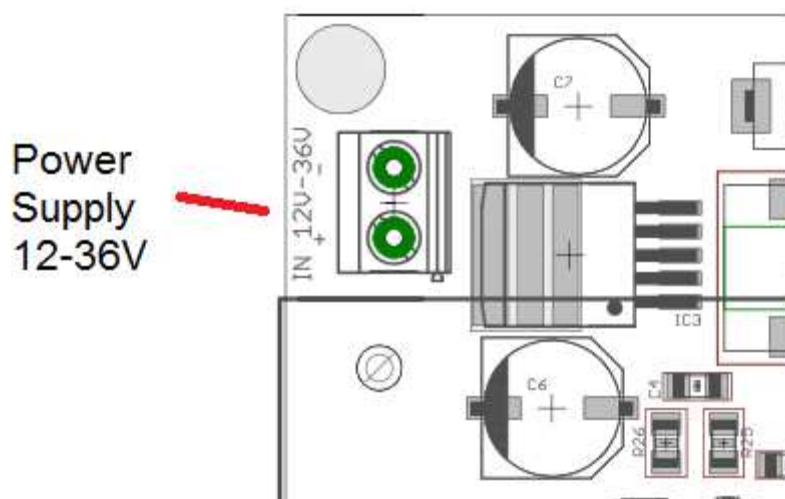

Delifery

- Current version of the manual
- Breakoutboard

Description of the breakout board

The breakout board enables the operation of up to 4 stepper motor or servo output stages on the UC400Eth.

For this the control Software Mach3 / UCCNC (not included) is used. The board has various inputs and outputs that can be individually set as many different configurations are possible. Depending on the selected configuration, additional functions are available, such as control of a frequency converter via an analog signal of 0-10V or 0-5V, reference switch, spindle direction relay, up to 3 relay outputs and one Charge Pump.

All signals are protected by Optocouplers. All machine-side signals are rated from 5V to 30V, ensuring robustness and compatibility even with industrial sensors (PNP SENSORS).

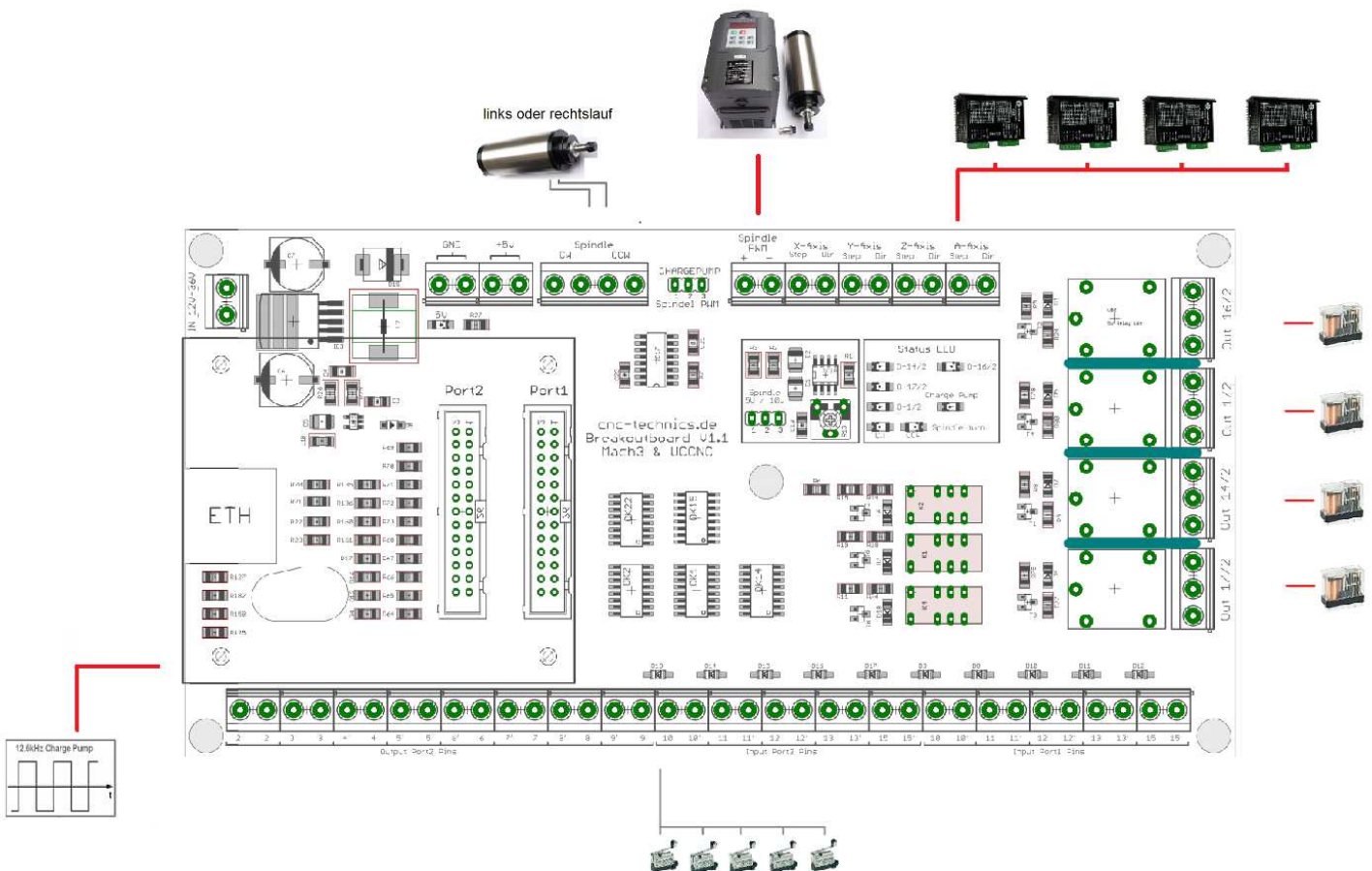

Commissioning

Installation of the UC400ETH

- ➔ The UC400ETH is screwed onto the 4 spacer bolts with M3 screws
- ➔ The operating voltage is supplied via the Breakoutboard

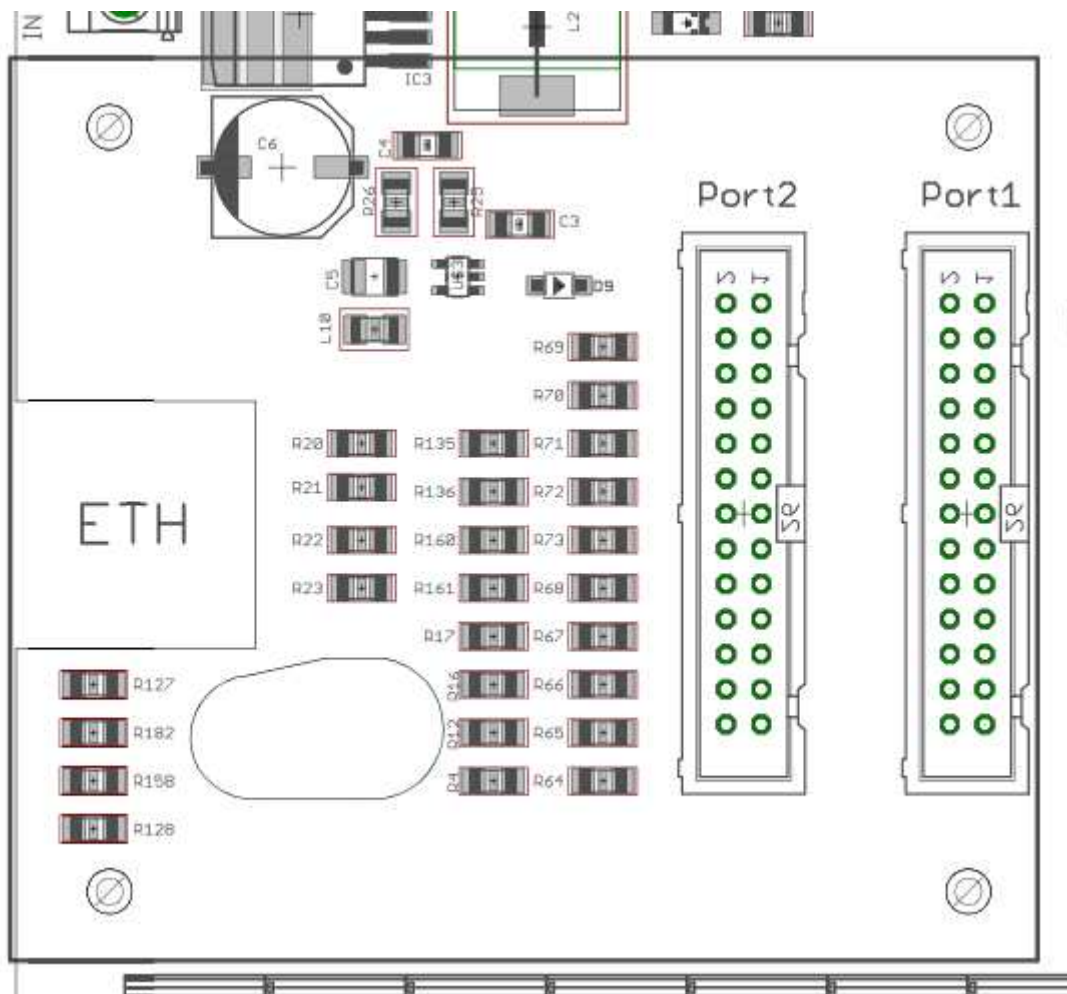

Inputs

Each input port is provided with its **Pin** number

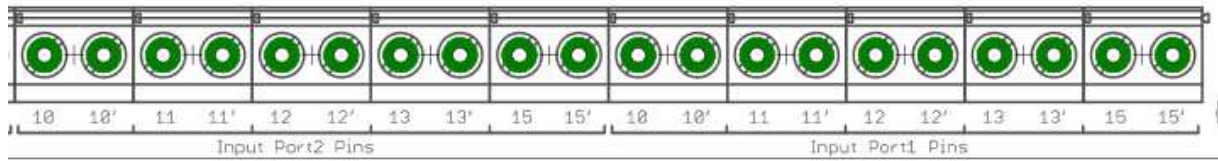

in Mach3/UCCNC at Ports & Pins has to put a hook in **Active Low**.

When the limit switch is actuated, it internally switches to ground and Mach3 detects a response at the input. PNP sensors switch with the switching voltage so they are also direct connected.

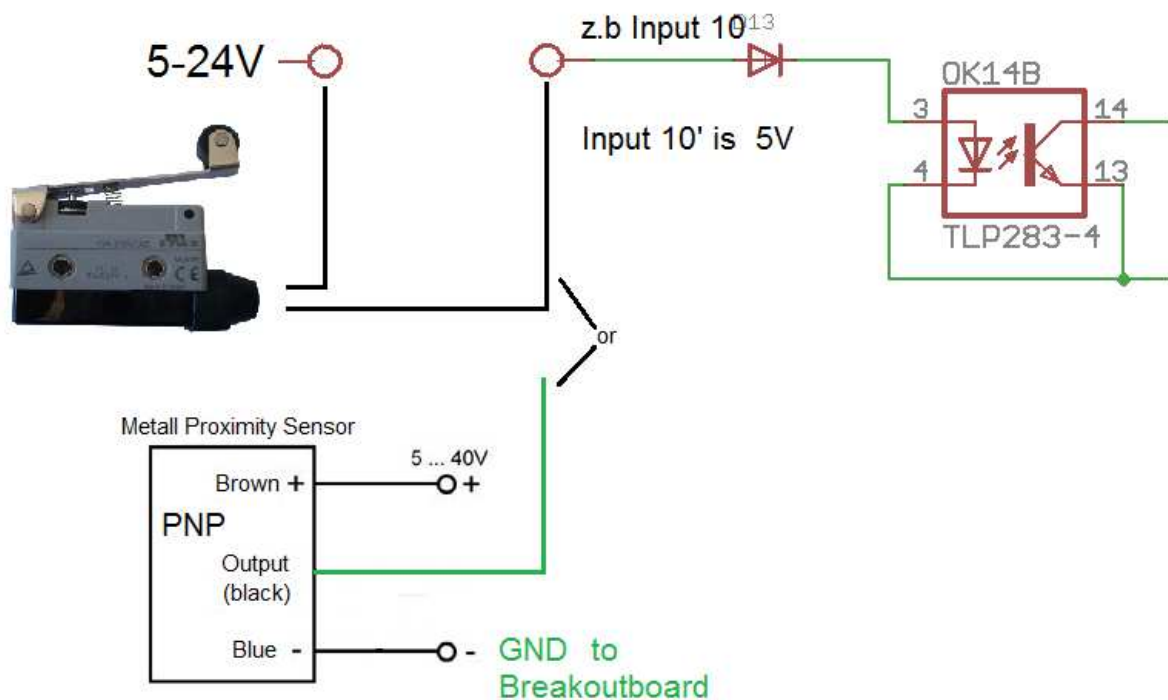

Outputs

Like the input port, each output port is also provided with a pin number and an associated * (output).

example

X32-1 is Number 6 = Port2/Pin6 and

X32-2 is Number 6* = Port2/Pin6

For 5V sensors, relays or similar loads you can put a bridge of 5V on the respective pin number, so you can use a power supply.

For switching max 50mA per output are available. If you need higher currents for switching you can connect inexpensive relay modules.

You can connect to any pin **without** * a direct voltage, max to 30V.

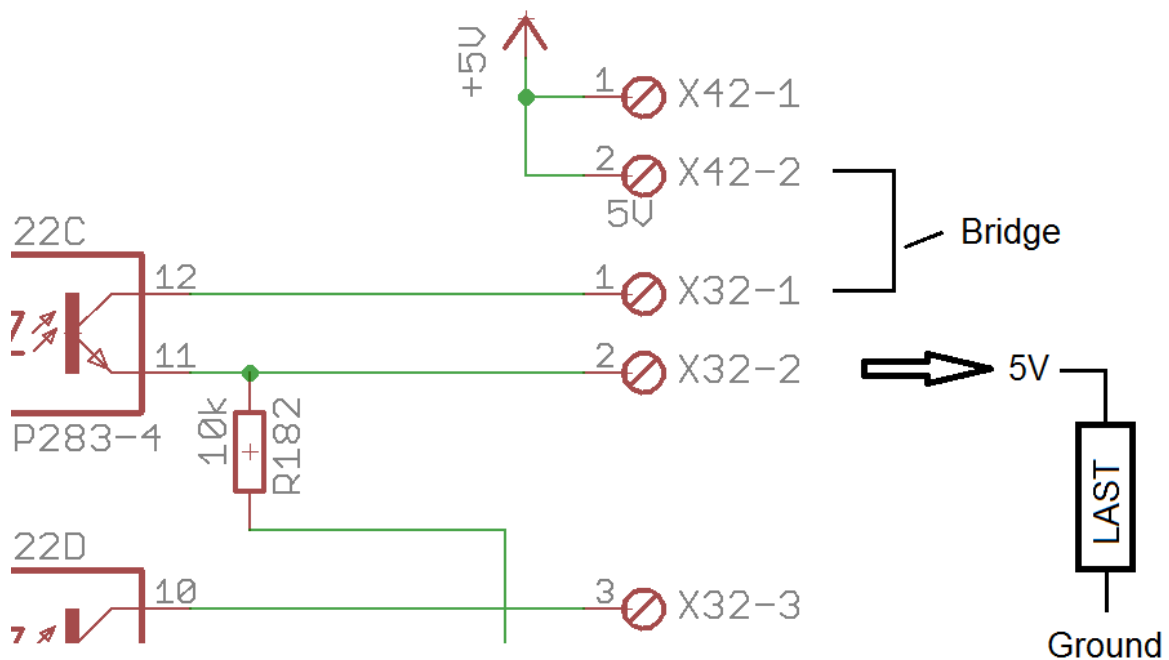

Integrate Outputs in Mach3

The Port Number and the Pin Number are used, the hook at enabled to enable output

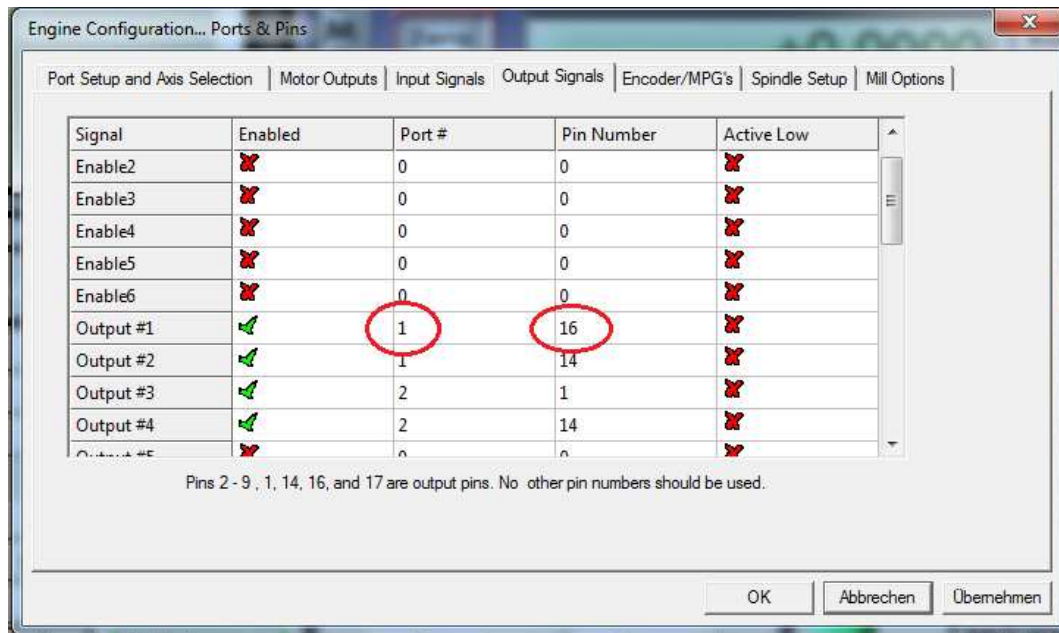

Set Axes in Mach3/UCCNC

These are fixed values that should not be changed.

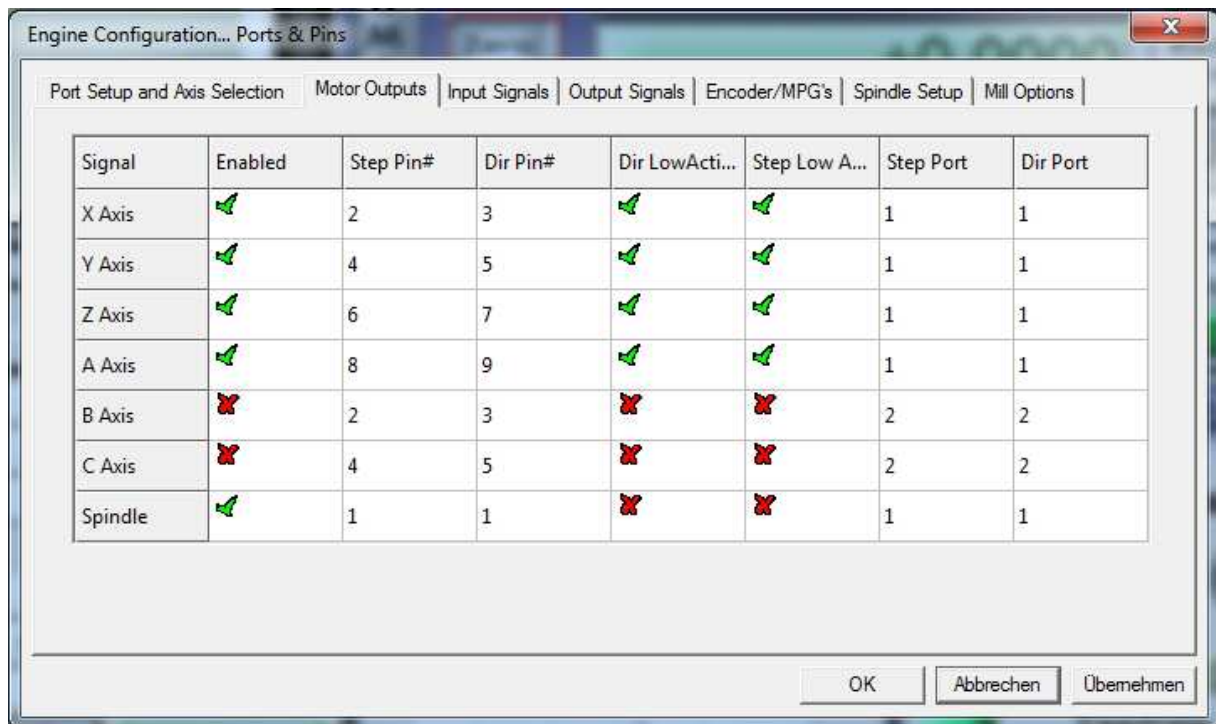

Driver Connection

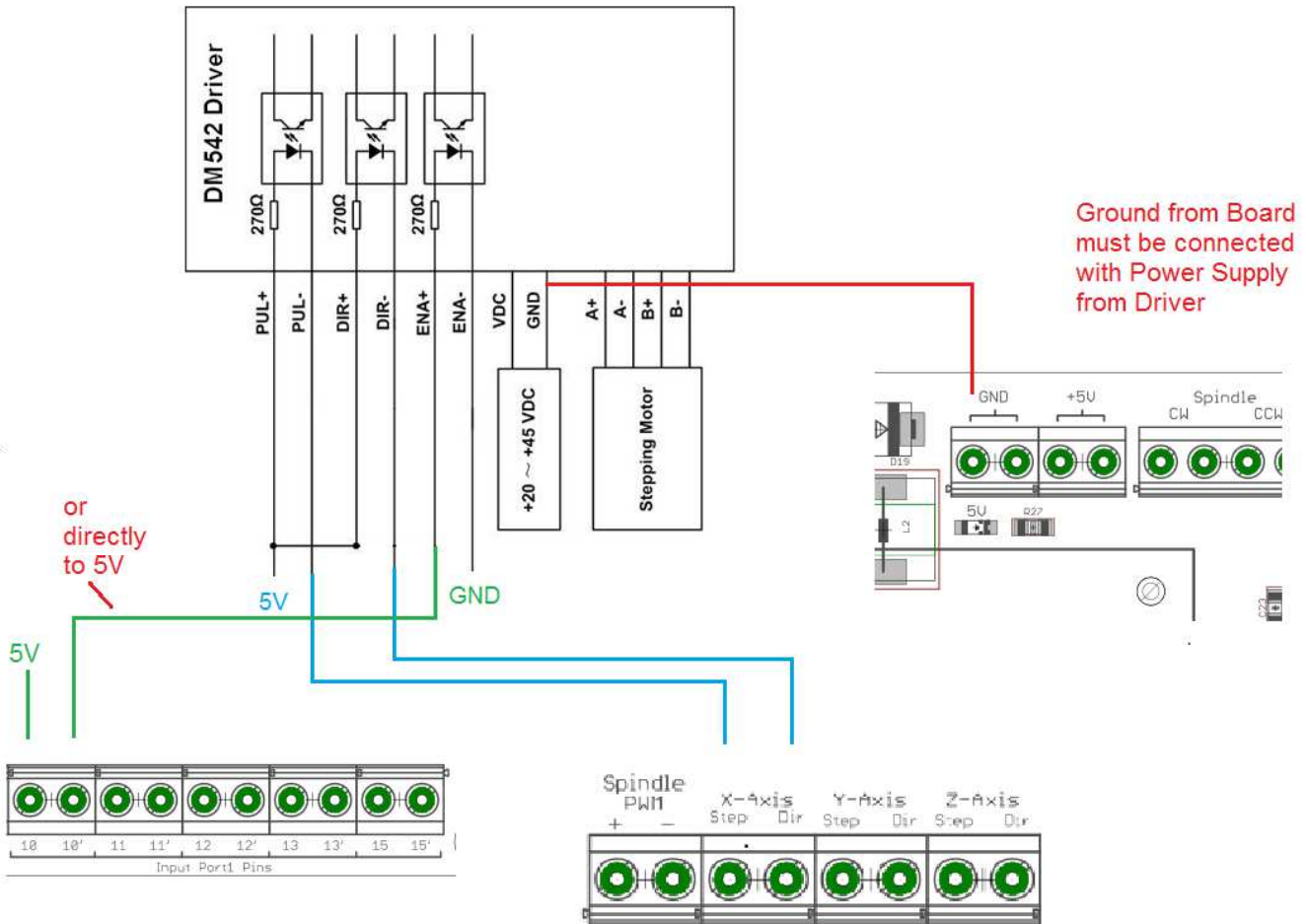

Set spindle

Port 1 / Pin 1 is the analog output for the spindle speed

A VFD frequency inverter for the analogue signal can be connected to the spindle output. Via jumper 1-2 = 5V or bridge 2-3 = 10V output signal at bridge

The Potentiometer R13 should not be adjusted he is set so that at 5V PWM output from the PC comes a 10V analog signal

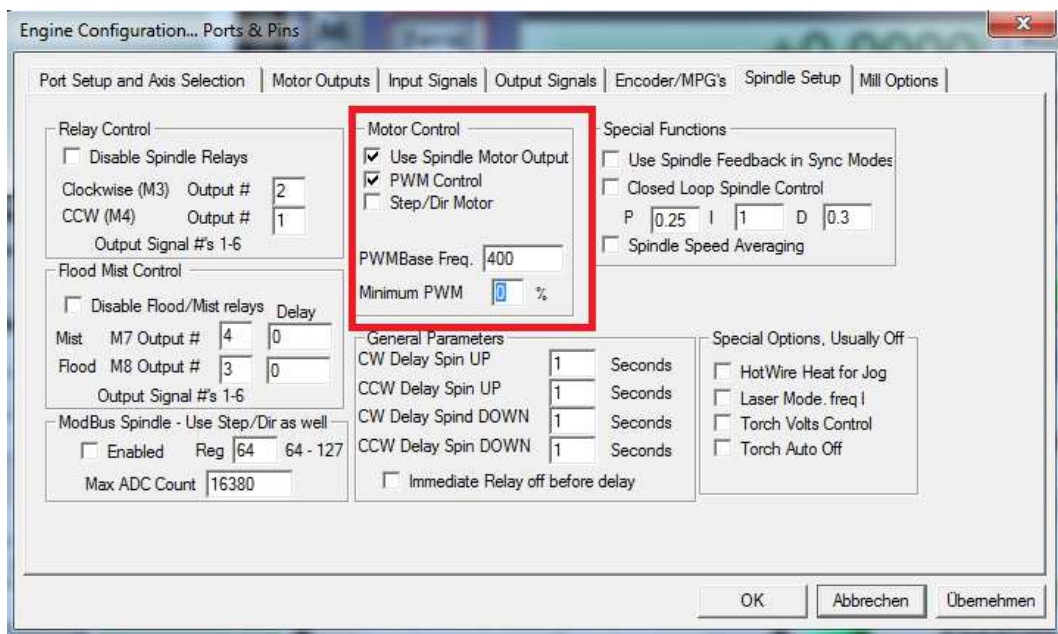
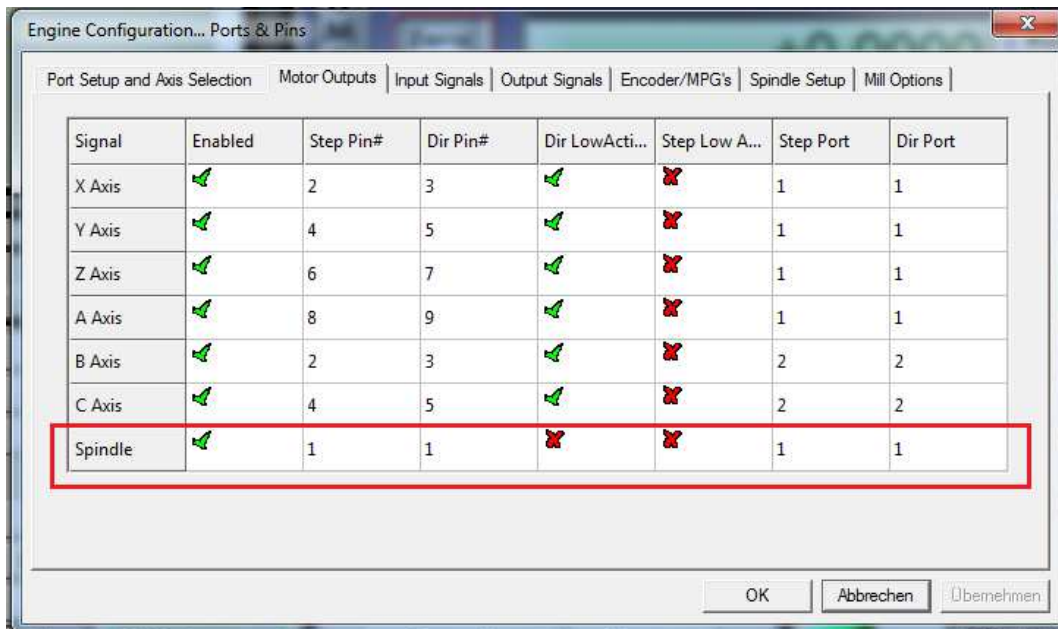
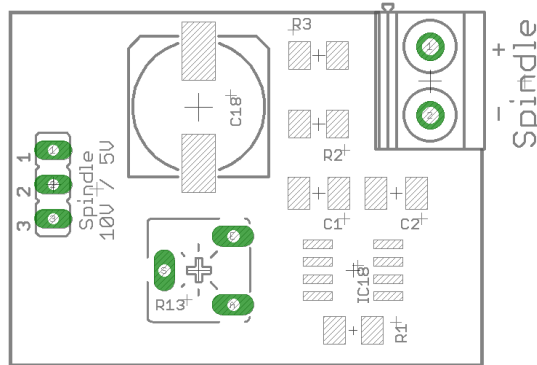

Spindle direction

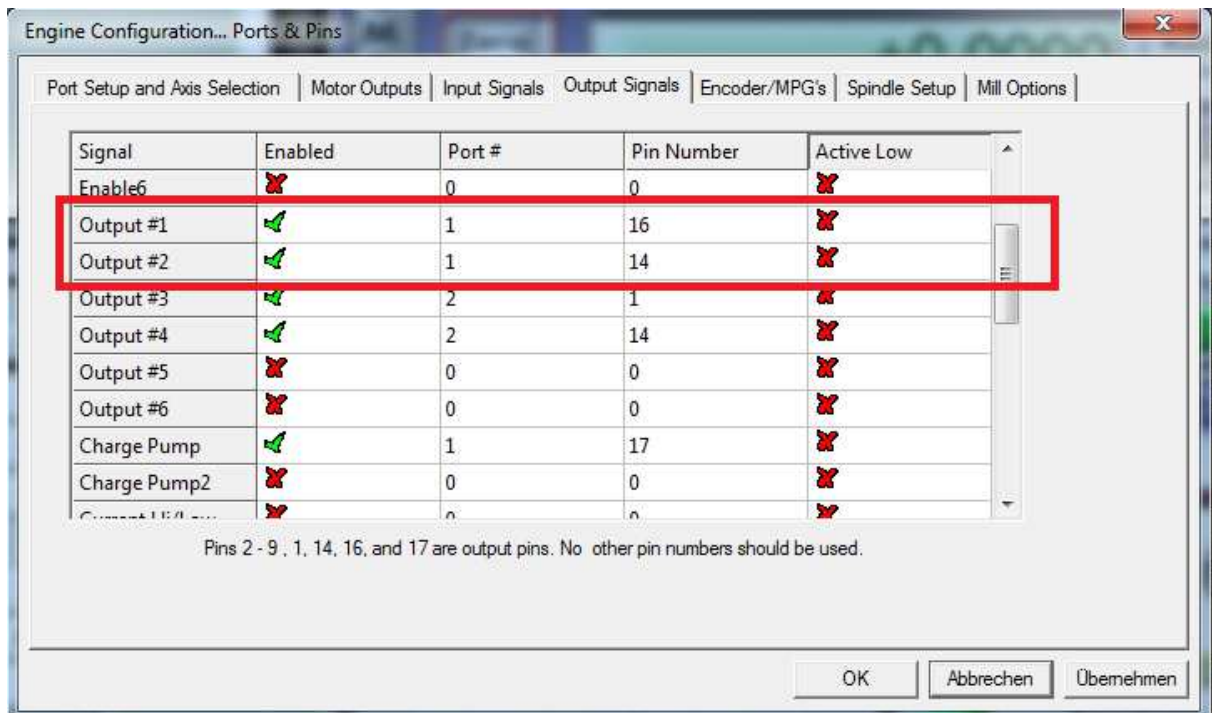
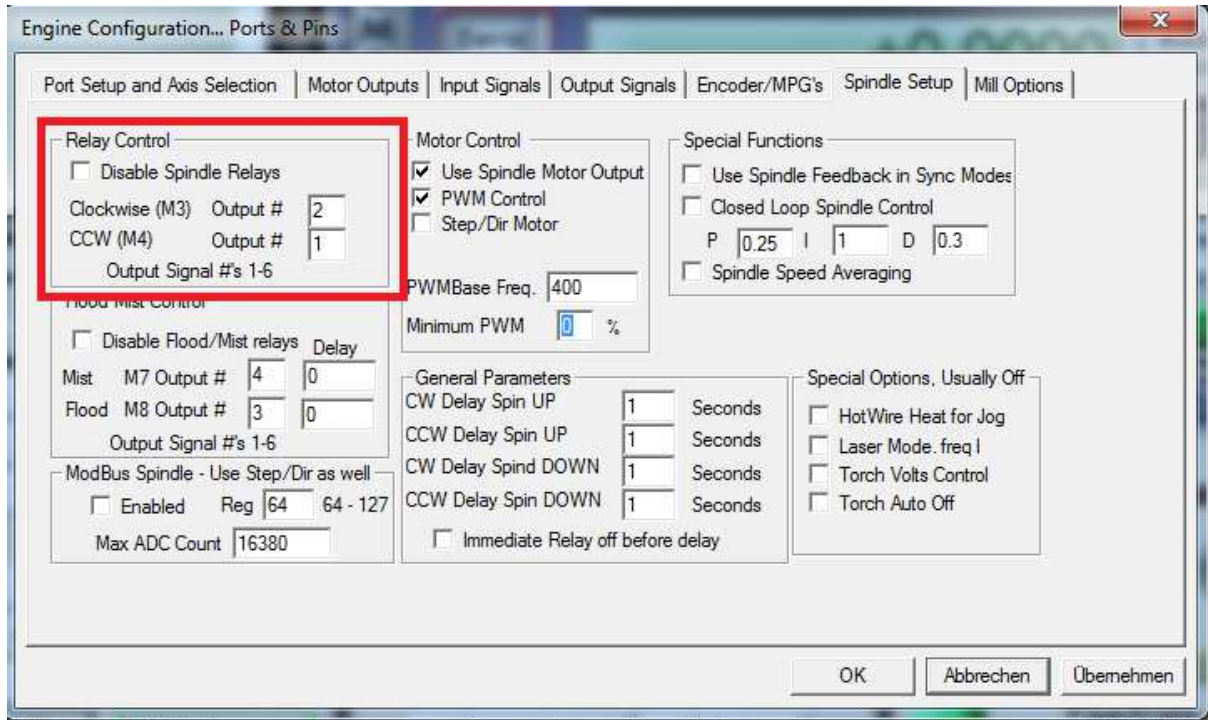

CW (clockwise) or CCW (counterclockwise) are switchable relay outputs.

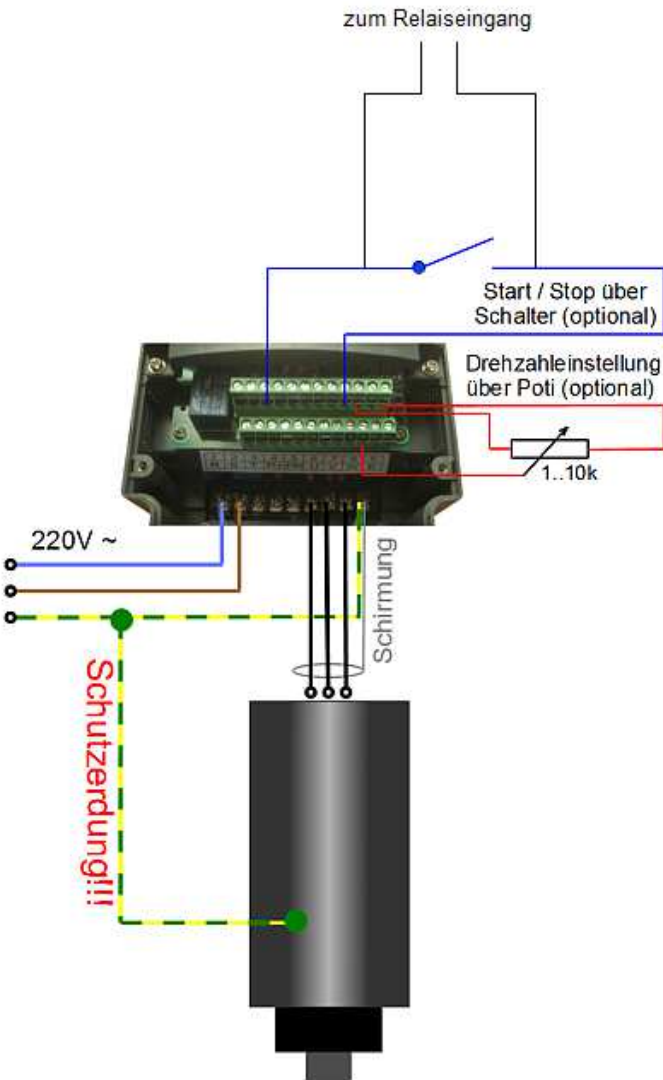
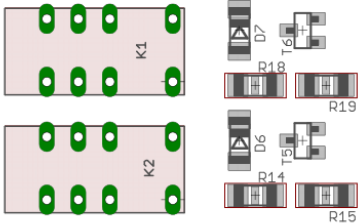
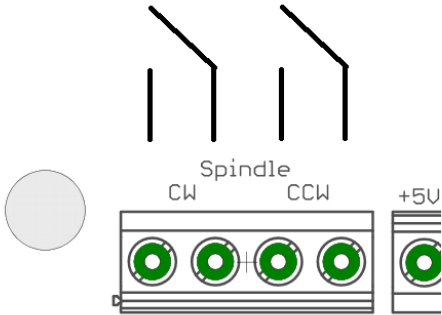

Spindle in UCCNC

RUN	TOOLPATH	OFFSETS	TOOLS	CONFIGURATION	DIAGNOSTICS	CAM	HELP
AXIS SETUP	I/O SETUP	I/O TRIGGER	GENERAL SETTINGS	APPEARANCE	PROFILES		
X-AXIS	Y-AXIS	Z-AXIS	A-AXIS	B-AXIS	C-AXIS	SPINDLE	AUX ENC.

PWM spindle

PWM pin: port: Active low
Dir pin: port: Active low
PWM frequency (Hz):
PWM min duty (%): max (%):

Step/direction spindle

Step pin: port: Active low
Dir pin: port: Active low
Step per rotation:
Acceleration (step/s²):

Spindle PID control

Index pin: port:
Index prescaler:

Encoder PPR: Reverse Enc. dir.
Encoder A pin: port:
Encoder B pin: port:

Spindle velocity (1/min): Min. Max. Use pulleys Pulley no.:

Spindle relay output enabled

M3 relay pin: port: Active low
M4 relay pin: port: Active low
M3 delay after on (ms):
M3 delay after off (ms):
M4 delay after on (ms):
M4 delay after off (ms):

Flood/Mist relay outputs enabled

M7 relay pin: port: Active low
M8 relay pin: port: Active low
M7 delay after on (ms):
M8 delay after off (ms):
M9 delay (ms):



Relaisoutput

There are 4 Relay Outputs up to 230V / max 10A (2,2KW at 230V) available
PORT 2 → Pin 1,14,16 oder 17

Attention: do not connect switching power supplies because they have a very high inrush current, the relay contacts may be defective

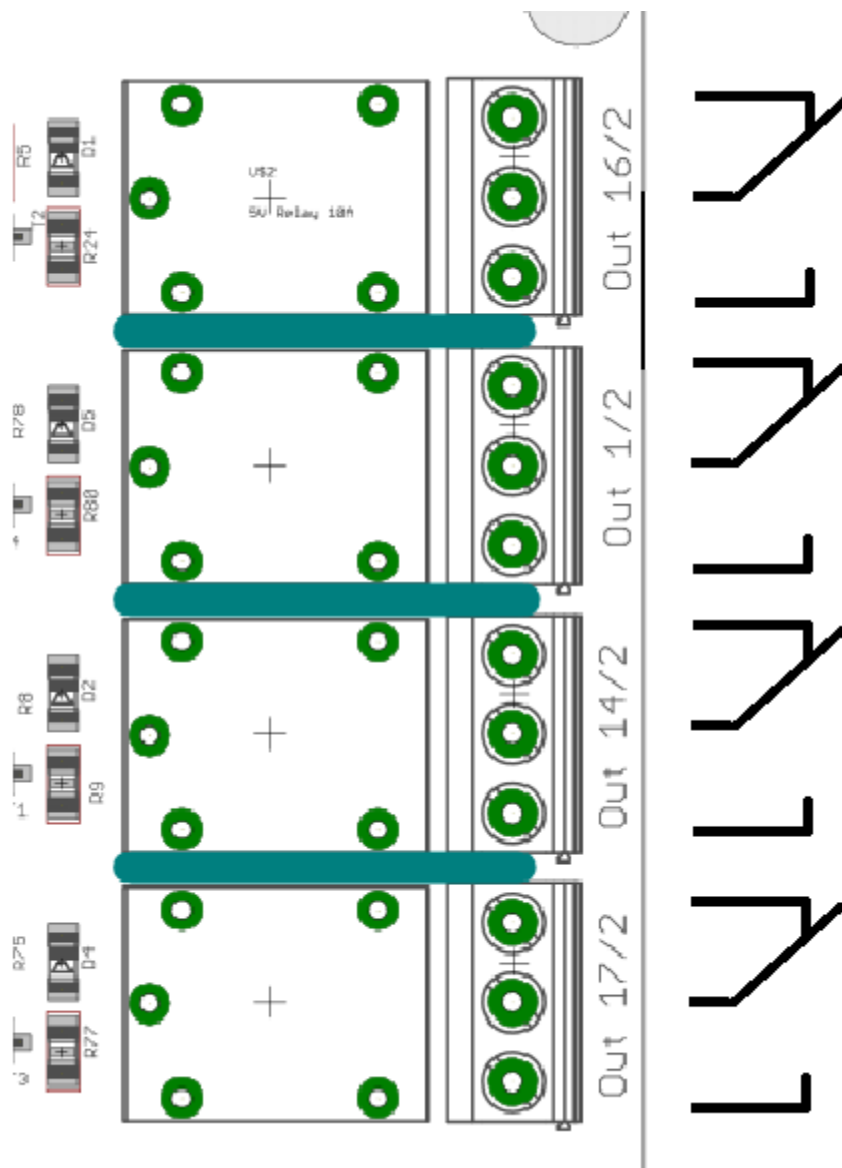

Statusdisplay

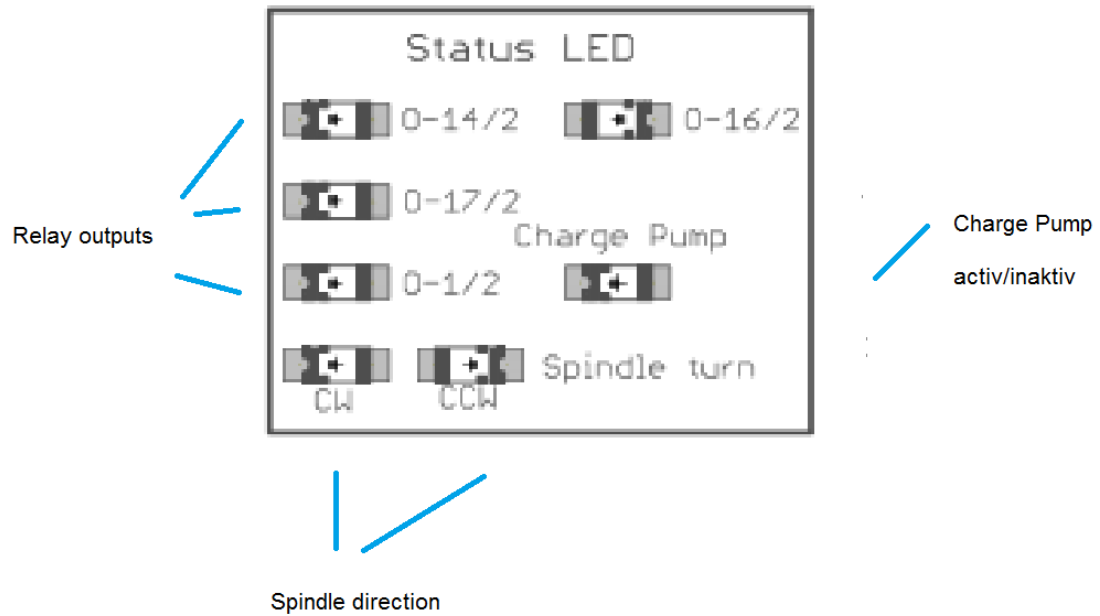

Charge Pump

This setting can be enabled or disabled

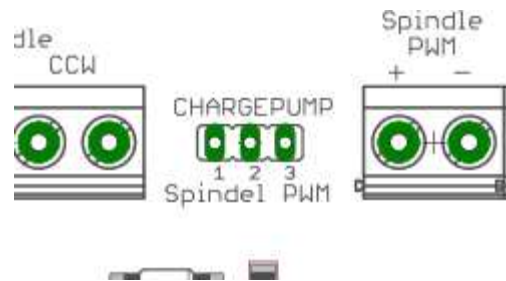

If the **jumper** is set to **1/2** the board will be activated without protection and all will remain Tensions and controls are maintained even if Mach3 makes a reset.

If the **jumper** is set to **2/3**, the breakout board will be controlled by Mach3 via the 12.5Khz signal. That is, only after the reset of Mach3 is deactivated, the board is active. All components are supplied with 5V or 12V. For this you have to make the following settings in Mach3:

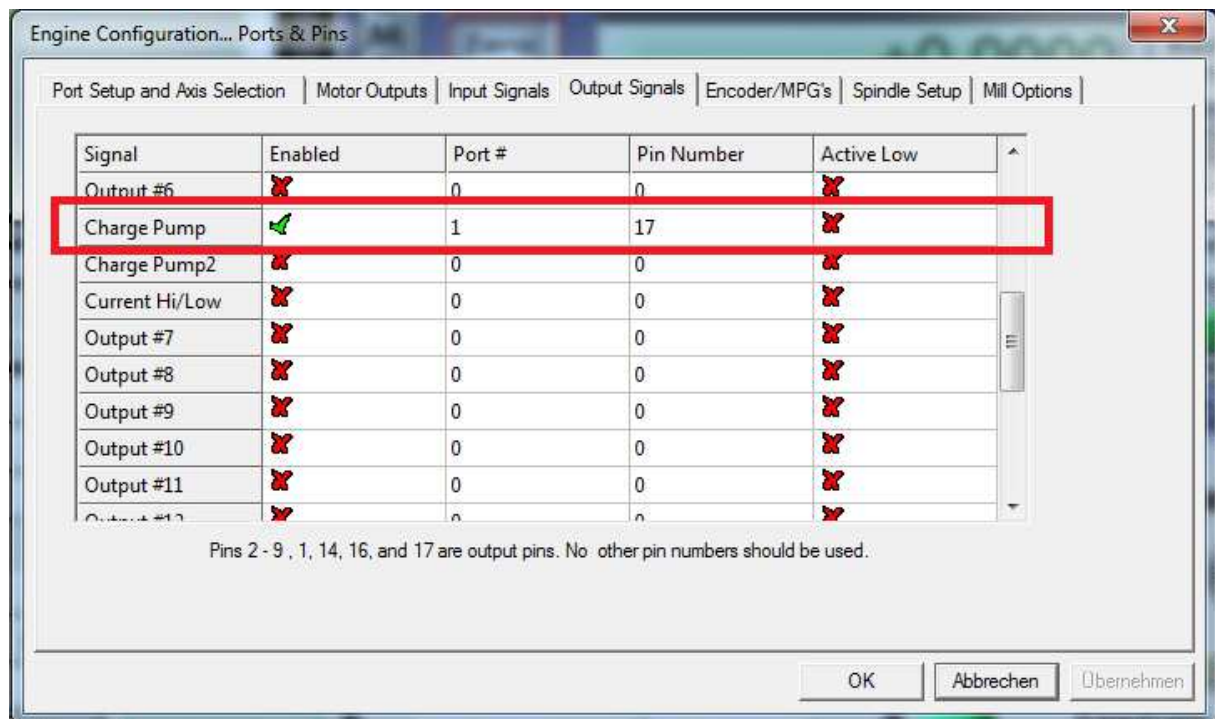

RUN TOOLPATH OFFSETS TOOLS **CONFIGURATION** DIAGNOSTICS CAM HELP
 AXIS SETUP **I/O SETUP** I/O TRIGGER GENERAL SETTINGS APPEARANCE PROFILES

E-stop pin: 0 port: 0 Active low
 Probe1 pin: 0 port: 0 Active low
 Probe2 pin: 0 port: 0 Active low
Charge1 p. pin: 17 port: 1 Active low
 Charge2 p. pin: 0 port: 0 Active low
 Charge pump always on
 Current hi/low: 0 port: 0 Active low
 Laser output: 0 port: 0 Active low

MPG A pin: 0 port: 0
 MPG B pin: 0 port: 0
 MPG prescaler: 1 MPG filter const.: 10
 MPG speed multiplier: 10
 Attach JRO to MPG

Enable THC control
 Arc on pin: 0 port: 0 Active low
 THC up pin: 0 port: 0 Active low
 THC down pin: 0 port: 0 Active low
 Min. height: 0 Max. height: 10
 THC feedrate (Units/min): 1000
 Control THC even if the THC on signal is not active
 Enable THC Delay Delay (sec): 0
 Enable THC anti dive Threshold (%): 0
 Enable THC anti down
 THC en. out pin: 0 port: 0 Active low
 An. dive out pin: 0 port: 0 Active low
 An. down out pin: 0 port: 0 Active low

Apply settings Save settings

 OFFLINE MODE
 CYCLE START
 SINGLE LINE
 FEED HOLD
 CYCLE STOP
 RESET